



GUANGDONG UNIHOPPER PRECISION TECHNOLOGY GROUP CO.,LTD

Operating center: Rm2404 Building B, Fengxing Plaza, No.242, Tianhe Rd, Tianhe District, Guangzhou City

Headquarter: Unihopper industrial park, No.9 Chuangye road, High-tech Industrial Development Zone ,Zhaoqing City, Guangdong Province, China

TEL: +86-758 3212918/3212919

FAX: +86-758 3212921

Email: pansheng@unihopper.biz

 [www.unihopper.biz/en](http://www.unihopper.biz/en)



Official wechat



Official website

On the premise of not influence the function and uality,Grasshopper reserves the right of changing the size,outlook without notice.  
There will be a little color difference between the product in presswork and definite object.The correct size of the product subject to definite object.



# WARDROBE



Designed by UNIHOPPER

WARDROBE





Unihopper Intelligent industrial park

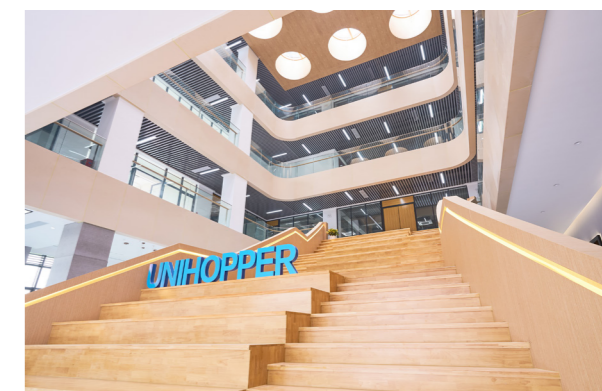

Unihopper R & D Building

# MILESTONES

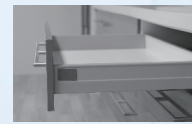

**2003**

Unihopper founded the company in Guangzhou, and launch the first generation one-way soft closing drawer box.



**2007**

Unihopper founded a union design group with designers from Europe and Columbia, and successfully launch the second generation two-way soft closing drawer box. The concept of twoway soft closing became popular around world ever since.

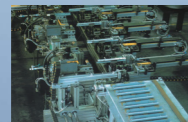

**2005**

Unihopper decided to invest with the advanced technology from Europe and construct the production base in FOSHAN of China.

**2010**

Unihopper successfully researched and developed the third generation interactive two-way soft closing drawer box and synchronize conceal slide.



**2015**

Unihopper successfully researched and developed the fifth generation interactive two-way soft closing drawer box-Magic box, and successfully hosted the "Night of Unihopper" in Beijing wardrobe annual conference.



**2013**

The union design group successfully researched and developed basket and wardrobe storage system (MOKA).

**2017**

Unihopper successfully hosted the second "Unihopper summit conference". Same time, Unhopper Business College was founded.

**2016**

Unihopper successfully hosted "Unihopper summit conference" in Guangzhou, and announced Unihopper would globalize the brand.

**2019**

Unhopper successfully hosted the third "Unihopper summit conference", and founded the new Unihopper production base and Unihopper brandday. Same year, Unihopper researched and developed the Phantom kitchen storage system and Co-box.



**2020**

Unihopper become one of the home decoration drafting committee for Hinge, slide and basket. In the same year, Unihopper won the National High-tech Enterprise. Vanka, COKA have been introduced to the market.

**2021**

Unihopper new production base put into use officially. LINA, HUGGEN have been introduced to the market.



**2022**

Unihopper international R&D center and the flagship showroom in the new headquarters fully open to the public, same time, Unihopper establish product R&D centre and product laboratory together with Vanke caizhu.

**2023**

We held the first "Unihopper Cup" National Terminal Designers Competition, initiating the first action in the industry by making a solid sound for the professional home designers who stand as a group of product end-user

# BRIEF INTRODUCTION

Unihopper, a high-end customized home brand and the provider for comprehensive solutions of hardware supporting, implements the "Belt and Road" global development strategy to develop the global market. Offering the Uni-products, Uni-design, and Uni-service to every corner of the world.

After years of development, Unihopper has sole agents in dozens of countries and regions around the world, such as Netherlands, Canada, Russia, Slovenia, Argentina, Korea, Iran, Spain, Portugal, Ireland, Saudi Arabia, Colombia, South Africa, India, Southeast Asia Regions and China HongKong, Macao and Taiwan regions and so on; and now, Unihopper has become a major suppliers for many well-known cabinet and home brands in the world.

In 2005, Unihopper set up a production base and established a large storage center in Nanhai city in China, and a new intelligent Uni-industrial park of more than 120,000 square meters will also be put into use in 2021. As one of the best name and provider for the high-end customized furniture hardware industry, Unihopper has always upheld the brand values of "European quality, Chinese price", and now, has become a leading brand popularizing in many home furnishing companies and consumers all over the world. In the future, Unihopper will increase more investment in space enlarging, strengthen multi-dimensional development including product application, intelligent scene introduction, online and offline channel integration, striving to become the best home storage master around consumers' life.



GS Quality Test Certification



ISO 9001 Quality Management Certification



Standards Maker of Kitchen Hardware Industry

# THE LAYOUT OF UNIHOPPER ALL OVER THE WORLD



# COMPANY VISION

## CORPORATE MISSION:

To meet people's yearning for a better life is the mission pursuit of Unihopper

## VALUES:

Integrity, altruism, struggle, innovation, understanding, common progress



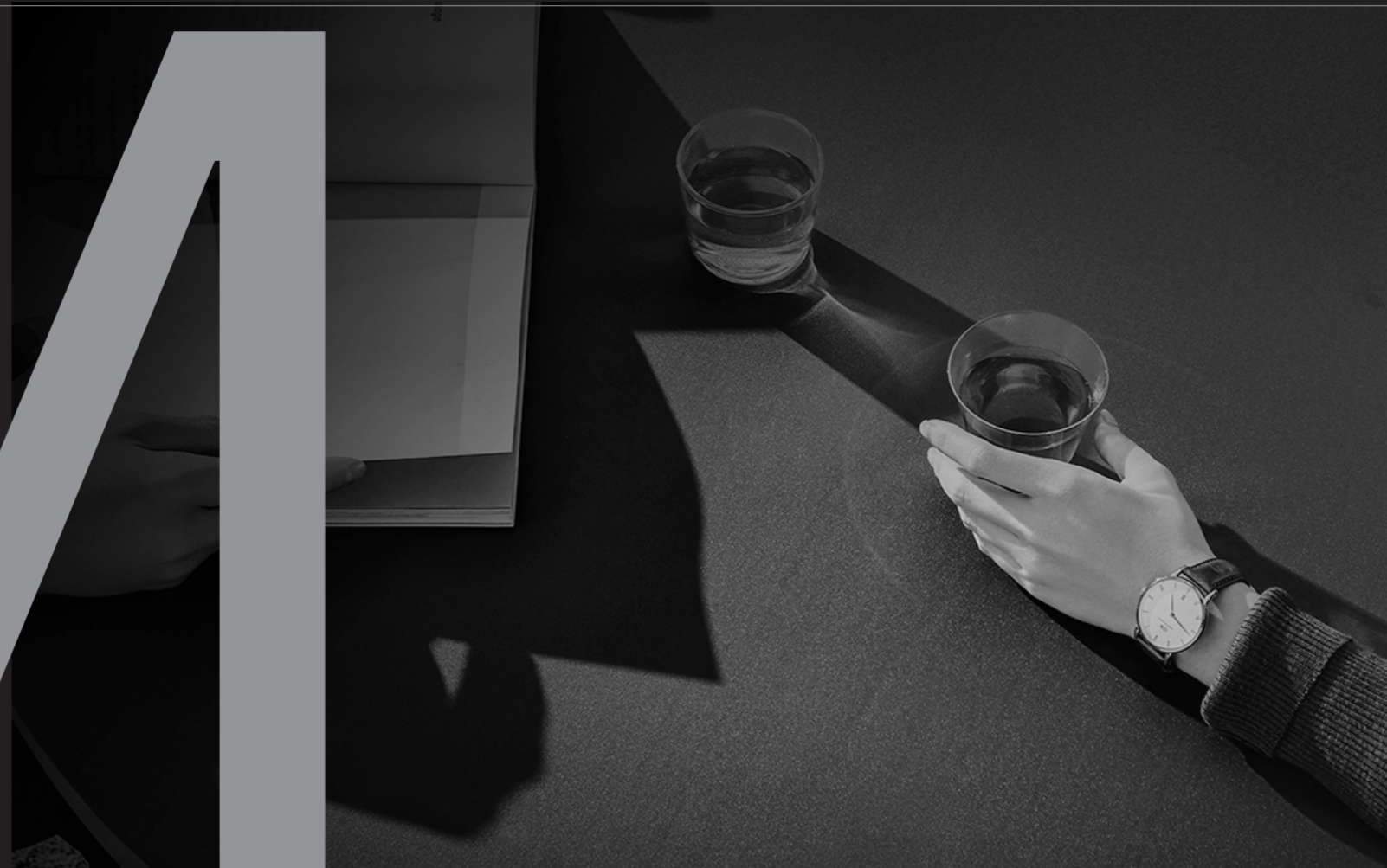

**MONIKA** STORAGE SYSTEM





NOBILITY IS NOT MATERIAL LUXURY, BUT A REFINED ATTITUDE TO LIFE.



# MONIKA STORAGE SYSTEM

MONIKA COMBINES ELEGANCE WITH PRAGMATISM TO MEET ALL EXPECTATIONS OF QUALITY LIFE AND IS THE WAY WE HAVE LONG LOOKED FORWARD TO IT.





MONIKA /  
Leather multifunctional storage box



EXTRAORDINARY VISUAL ENJOYMENT WITH  
FUNCTIONAL AND STYLISH DESIGN, TO  
STORE THE JEWELRY PERFECTLY.





MONIKA /  
Leather flat storage box

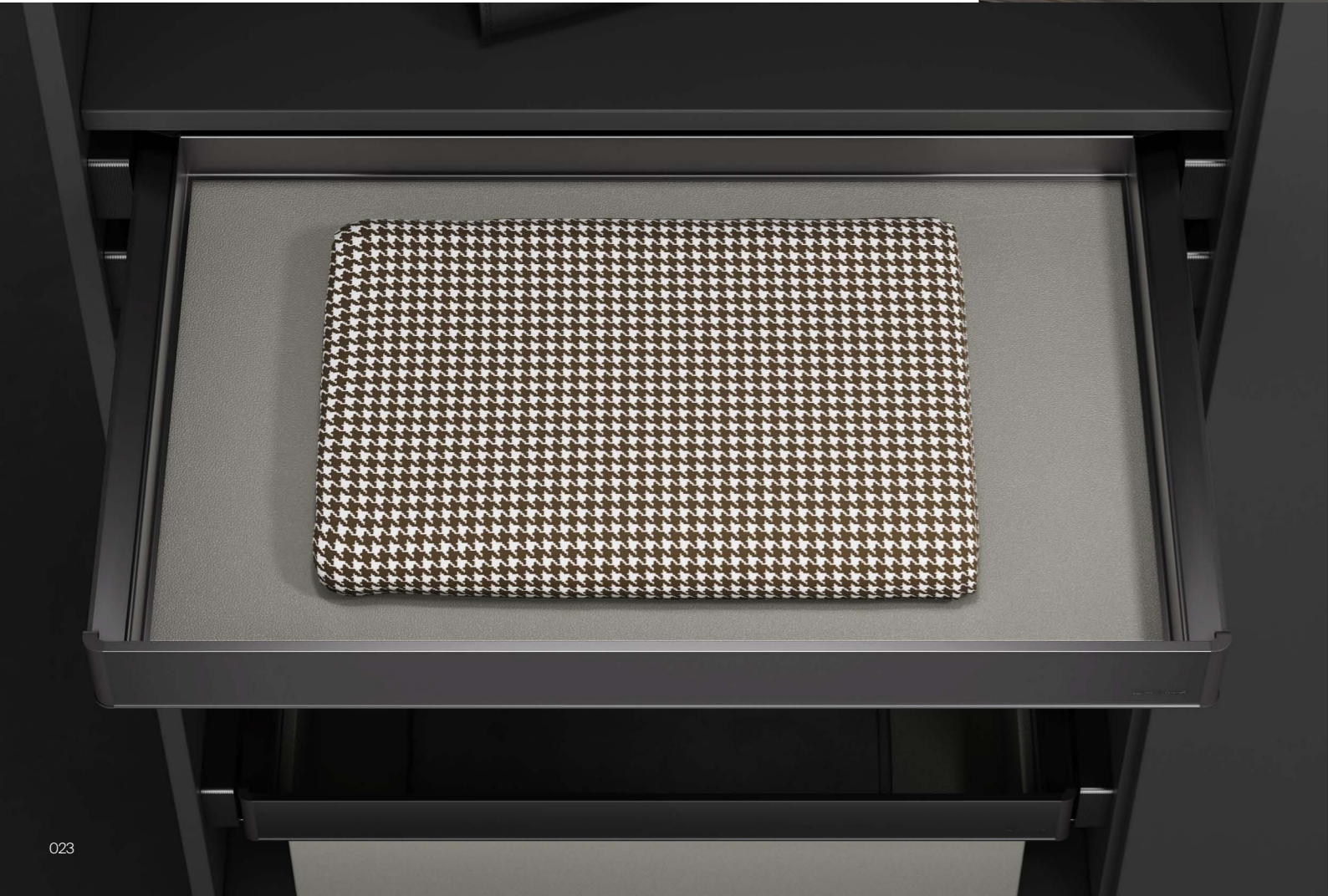

# The beauty of orderliness.

“It feels like a luxury touch”, the elegant design is not restricted by any times and tide, but makes your wardrobe full of charming.



MONIKA /  
Leather underwear storage box

THE LEATHER STORAGE BOX KEEPS YOUR UNDERWEAR A PERFECT STORAGE.



LIFE HAS A THOUSAND  
KINDS OF ATTITUDE.







THE TROUSERS RACK WITH ANTI-SLIP DESIGN, KEEP THE PANTS ORDERLY AND MAKE IT EASY FOR TAKING.

MONIKA /  
Trousers rack



MONIKA /  
Trousers rack

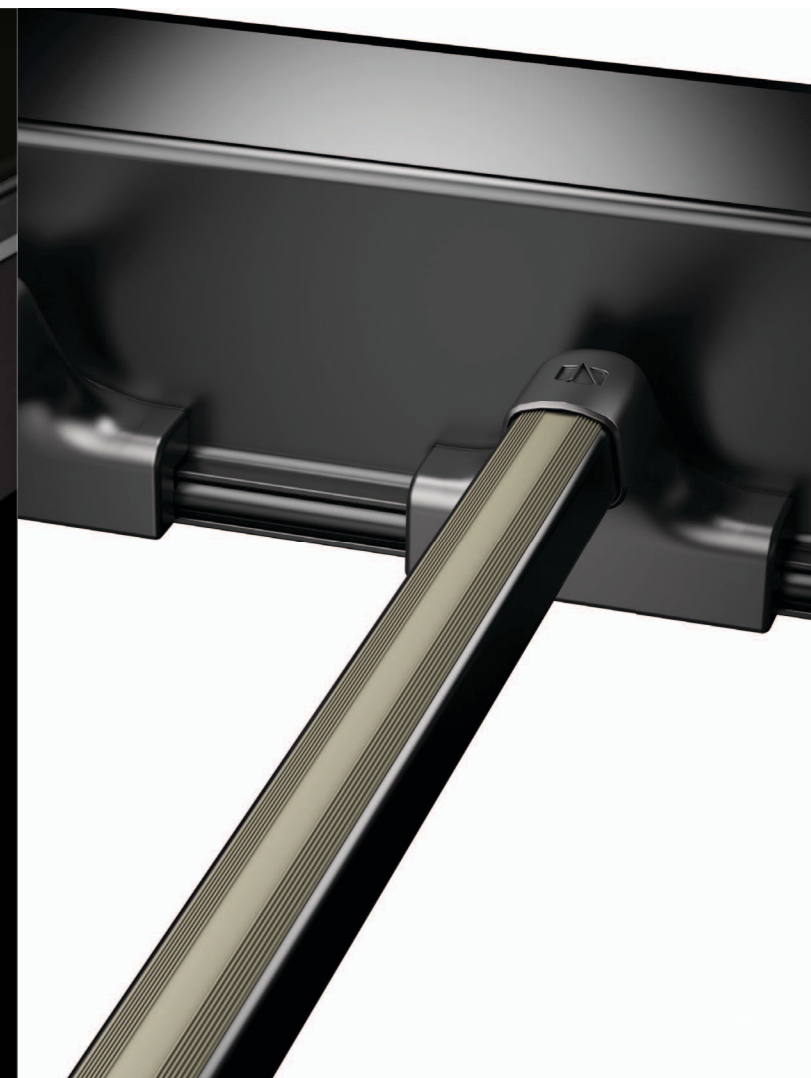



MULTI-FUNCTIONAL AND CABINET-STYLED DESIGN IS UTILITY TO MAKE GOOD USE OF THE WARDROBE SPACE.

MONIKA /  
Leather storage bag



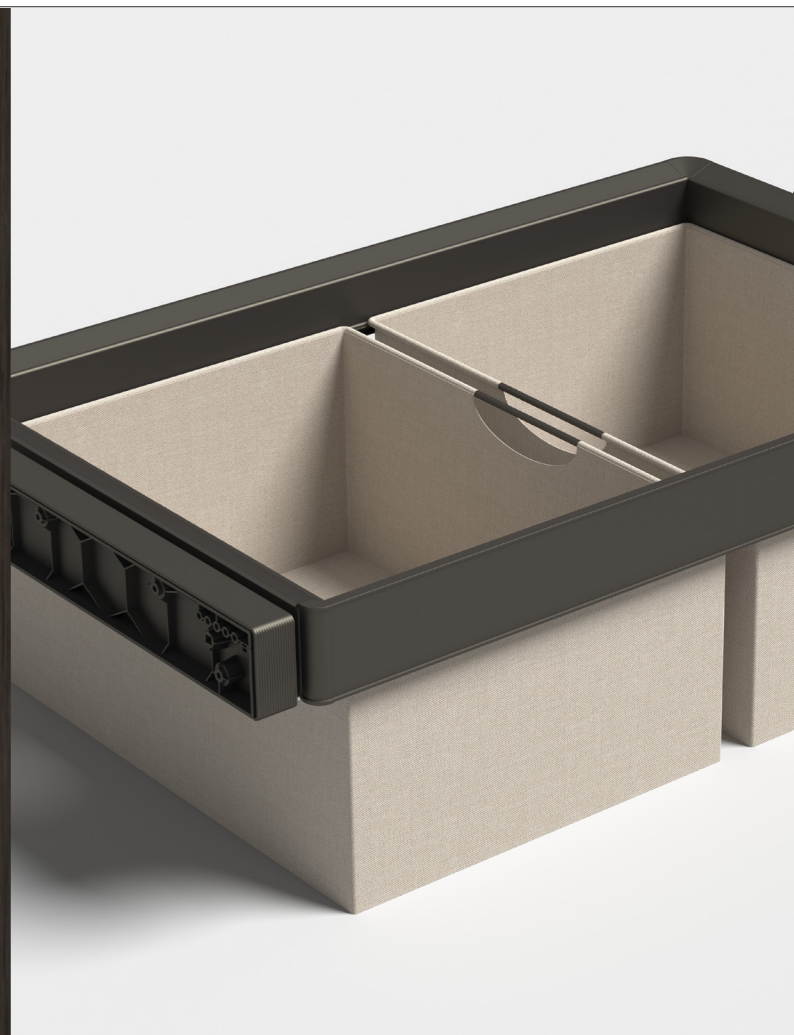

MONIKA /  
Laundry bag

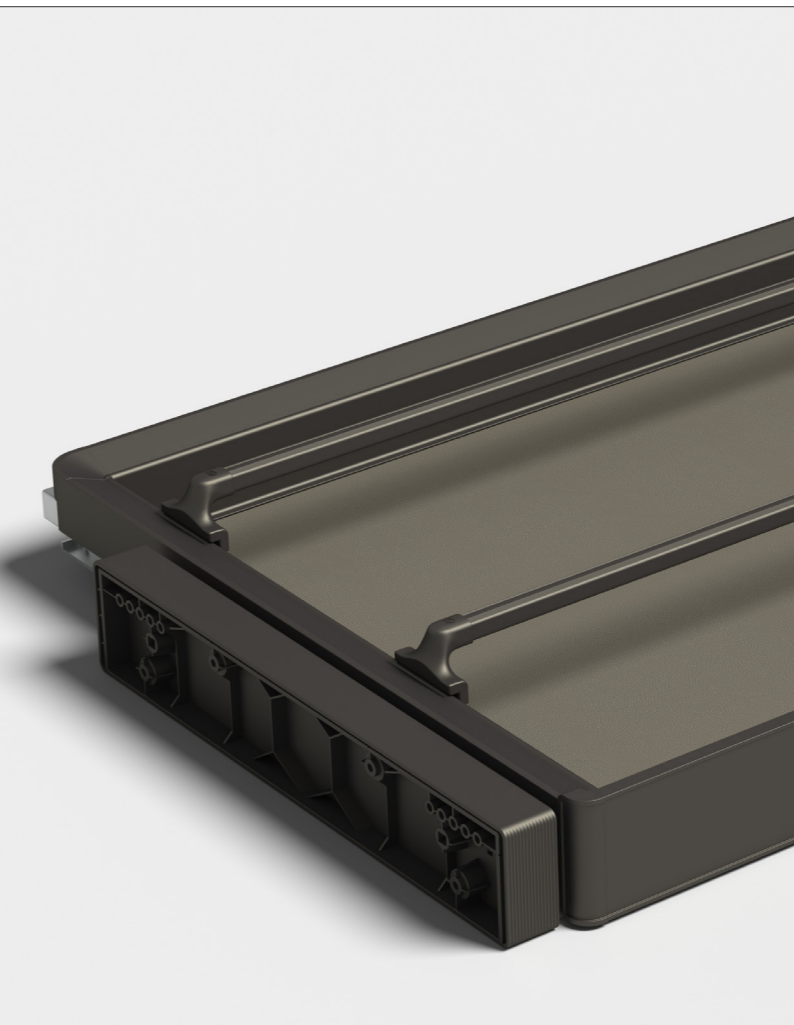

MONIKA /  
Shoes rack



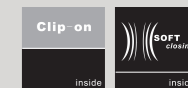

→ FEATURES

- Easy clip on way, free from most of the hinges
- The upgrade to Gun Grey color, adding the metallic to the whole product. Arc edge design, displaying the beauty of industrial design
- Color: Gun Grey



MONIKA LEATHER MULTIFUNCTIONAL STORAGE BOX

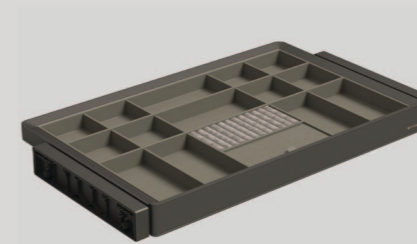

MODEL	CABINET W (mm)	WIDTH x DEPTH x HEIGHT (mm) With slides
WS4184S.060.GG	600	562~582x457x67
WS4184S.070.GG	700	662~682x457x67
WS4184S.080.GG	800	762~782x457x67
WS4184S.090.GG	900	862~882x457x67

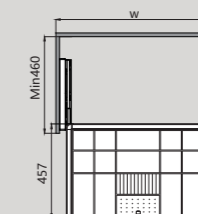

MONIKA LEATHER UNDERWARE STORAGE BOX

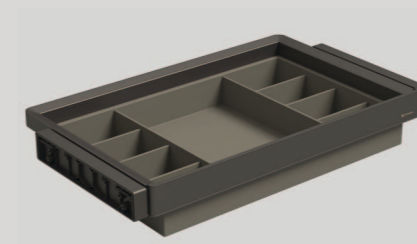

MODEL	CABINET W (mm)	WIDTH x DEPTH x HEIGHT (mm) With slides
WS4186S.060.GG	600	562~582x457x124
WS4186S.070.GG	700	662~682x457x124
WS4186S.080.GG	800	762~782x457x124
WS4186S.090.GG	900	862~882x457x124

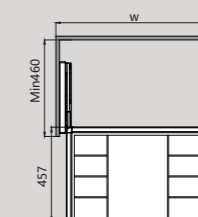

MONIKA LEATHER FLAT STORAGE BOX

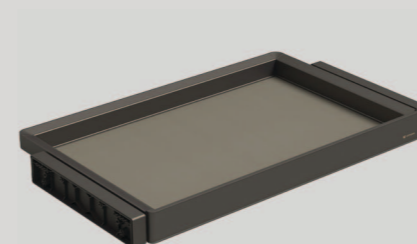

MODEL	CABINET W (mm)	WIDTH x DEPTH x HEIGHT (mm) With slides
WS4183S.060.GG	600	562~582x457x67
WS4183S.070.GG	700	662~682x457x67
WS4183S.080.GG	800	762~782x457x67
WS4183S.090.GG	900	862~882x457x67

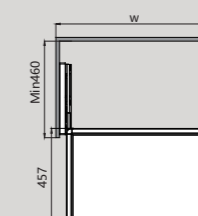



MONIKA TROUSERS RACK

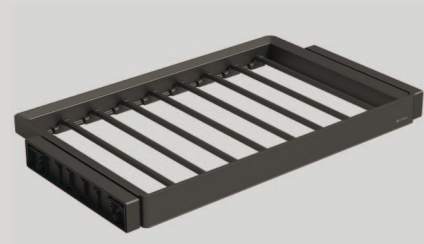

MODEL	CABINET W (mm)	WIDTH x DEPTH x HEIGHT (mm) With slides
WS4185S.060.GG	600	562~582x457x67
WS4185S.070.GG	700	662~682x457x67
WS4185S.080.GG	800	762~782x457x67
WS4185S.090.GG	900	862~882x457x67

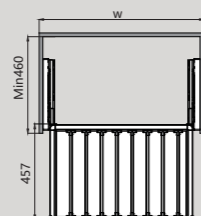

MONIKA LAUNDRY BAG

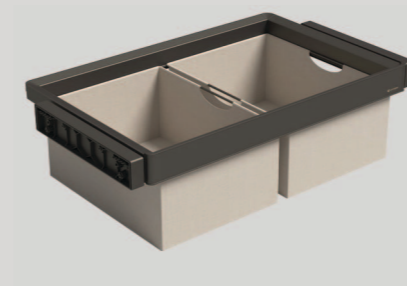

MODEL	CABINET W (mm)	WIDTH x DEPTH x HEIGHT (mm) With slides
WS4188S.060.GG	600	562~582x457x224
WS4188S.070.GG	700	662~682x457x224
WS4188S.080.GG	800	762~782x457x224
WS4188S.090.GG	900	862~882x457x224

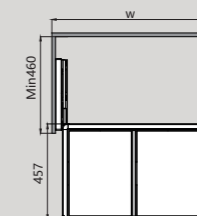

MONIKA LEATHER STORAGE BAG

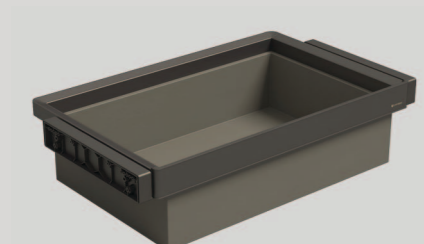

MODEL	CABINET W (mm)	WIDTH x DEPTH x HEIGHT (mm) With slides
WS4187S.060.GG	600	562~582x457x196
WS4187S.070.GG	700	662~682x457x196
WS4187S.080.GG	800	762~782x457x196
WS4187S.090.GG	900	862~882x457x196

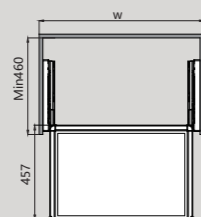

MONIKA SHOES RACK

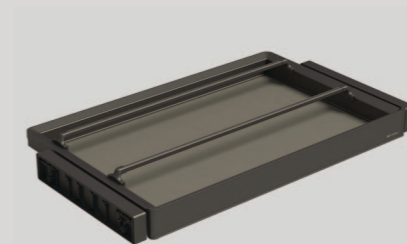

MODEL	CABINET W (mm)	WIDTH x DEPTH x HEIGHT (mm) With slides
WS4189S.060.GG	600	562~582x457x80
WS4189S.070.GG	700	662~682x457x80
WS4189S.080.GG	800	762~782x457x80
WS4189S.090.GG	900	862~882x457x80

